



The Effects of Improved Transportation Networks in Tanzanian Villages

Tundu: A Case Study

Produced for:

The World Wildlife Foundation
Dar es Salaam, Tanzania

The Village of Tundu

Tanzania National Parks
Udzungwa Mountains Division

As Presented By:

Adrienne Angelucci
Undergraduate of Landscape Architecture
Pennsylvania State University
Class of 2012

Abigail Thomas
Undergraduate of Landscape Architecture
Pennsylvania State University
Class of 2012

Under the Instruction of:

Larry Gorenflo, Ph.D.
Assoc. Professor of Landscape Architecture
Pennsylvania State University
University Park, Pennsylvania U.S.A.

Brian Orland
Professor and Director of the School of Architecture
and Landscape Architecture
Pennsylvania State University
University Park, Pennsylvania U.S.A.



The Interface between Humanity and Biodiversity Conservation: Villages near Udzungwa Mountains National Park

As is characteristic of the majority of Tanzanian settlements, many villages are bound by protected natural areas and fertile agricultural land. Settlements between natural areas and agricultural land are the source of many conflicts throughout the country. The socio-economic status of the majority of the people is directly related to the amount of pressure placed on both protected natural areas and fertile land. Firewood collection, illegal poaching, unregulated medicinal plant collection, and encroachment due to population growth and the need for agricultural expansion for both subsistence and economic purposes are major issues.

Located in the highly fertile Kilombero Valley, the village of Tundu is “sandwiched between the Udzungwa Mountains National Park, the Kilombero Sugar Plantations and the Selous Game Reserve. As observed through visits to Tundu, it is obvious that there are issues in regard to land use and land planning. In its present state, development in the village is irregular and unplanned. As the area continues to experience population growth (mainly attributed to the Illovo Cane Company), controlled and planned expansion will be necessary and should be integrated in order to promote a more balanced relationship between people and the landscape. The commonly accepted organizational system of roads is non-existent within Tundu, as is frequent in many Tanzanian villages. Buildings define the spatial character of the village and property boundary delineation nonexistent. The lack of a clear landscape organizational system hinders the interchange of people, products, and communication both within Tundu and between surrounding villages is inefficient. Inter- and intra-village economies and communications is negatively affected by this and hampers Tundu’s ability to adjust to their involvement and competition within local, national, and global markets and to to plan and design for effective and sustainable, population growth. Ultimately, an organized and sustainable road network will lay the foundation for future planning in response to continued population growth.s imperative that a well thought out circulation network be instated in Tundu for the benefit of future and present development.

The intent of this project is to evaluate and consider the possible locations and feasibility for the implementation of a local distributor road that extends from the main road that runs north to south and bisects the upper and lower portions of the village of Tundu. It will aim to meet these needs by establishing a circulation system that considers current roadway improvements and a proposal for the construction of a local distributor road as suggested by local planning officials.

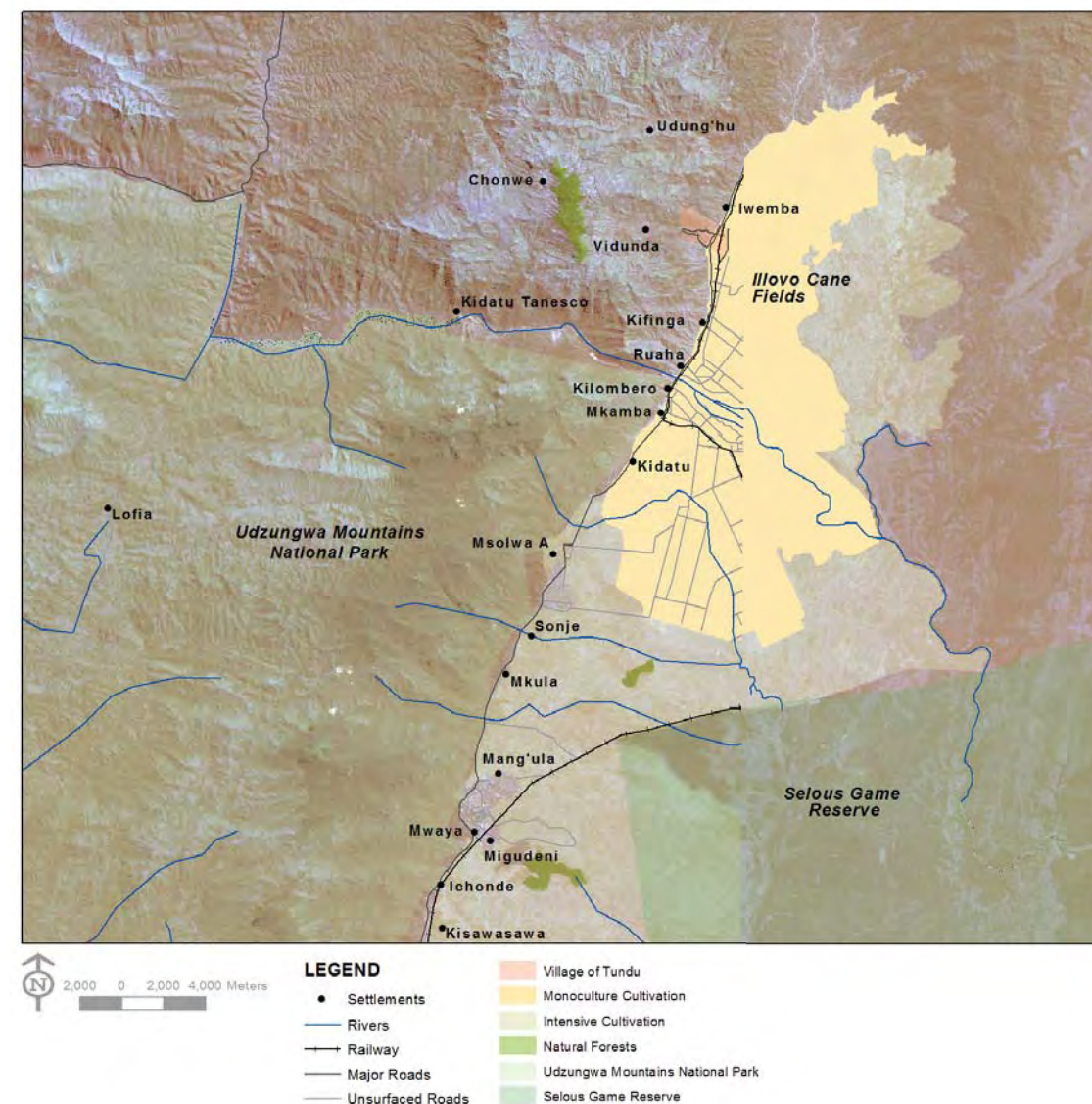

Photos Courtesy of Orland 2010

Photo courtesy of Illovo Cane Company

Existing Infrastructure & Important Village Destinations: Possible Village Access Points

- Legend**
- Rivers
 - Contours (20 Meters)
 - Railway
 - Major Paved Roads
 - Major Unsurfaced Roads
- Destinations**
- Notes**
- School
 - Church
 - Mosque
 - Mr. Muchinguzi (Witch Dr.)
 - Cinema
 - Bars
 - Shops
 - Bike Shop
 - Maize Cemetery
 - Butcher
 - CCM Office
 - Public Cemetary
- Tundu Land Use**
- CODE**
- Community Managed Forest
 - F Cemetery
 - V Reserve
 - Settlement
 - General Land
 - School
 - Market
 - Cemetary

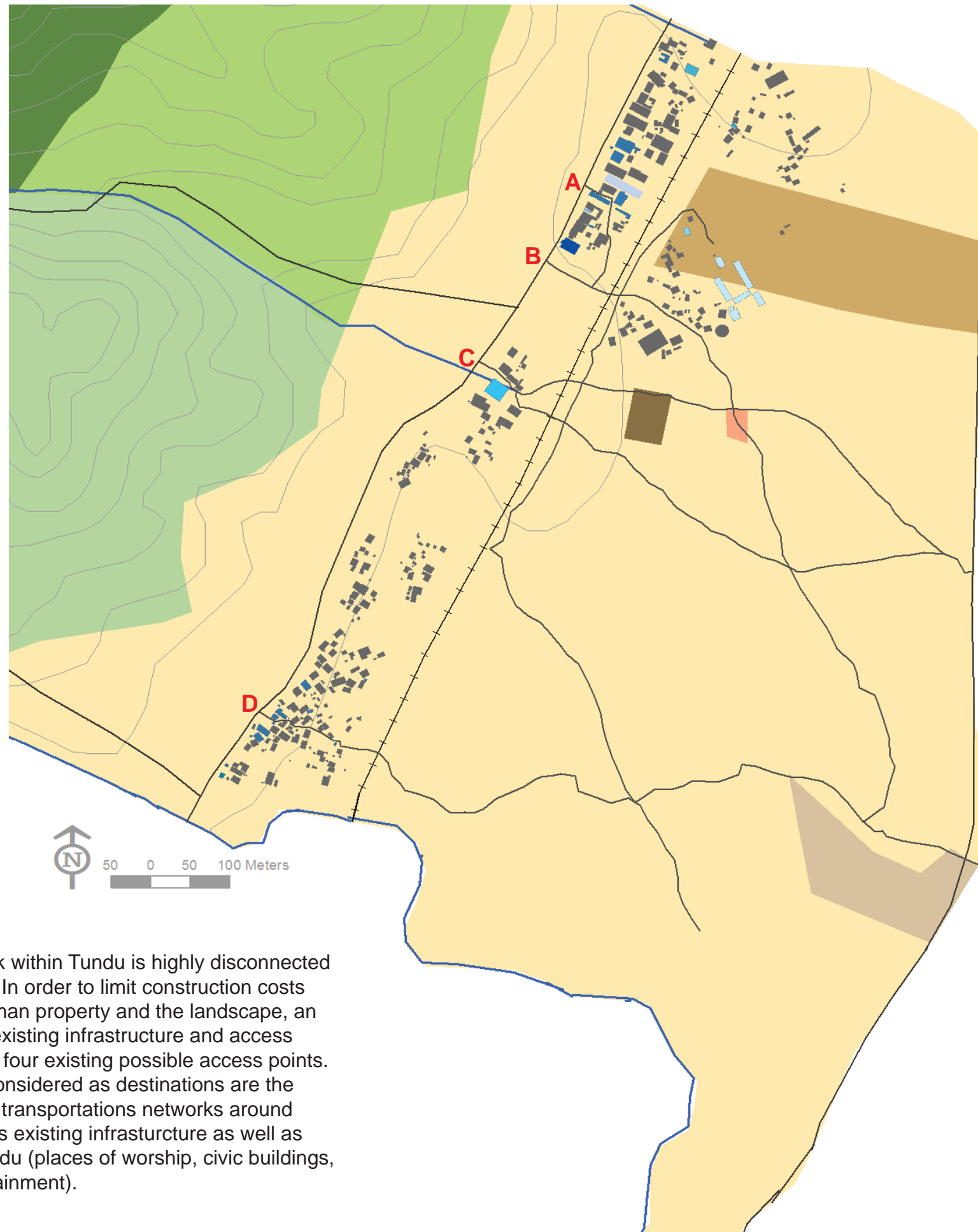

The current circulation network within Tundu is highly disconnected and lacks defined access points. In order to limit construction costs as well the encroachment on human property and the landscape, an evaluation and consideration of existing infrastructure and access points was completed. There are four existing possible access points. In addition, destinations were considered as destinations are the basis for circulation patterns and transportations networks around the world. The map above depicts existing infrastrucrture as well as important destinations within Tundu (places of worship, civic buildings, cemeteries, and places of entertainment).

- A** The variety of destination types within this dense protion of town make this access point ideal. While it is probable that improved access will lead to increased economic gain for surrounding businesses, this point may present limitations for the implementation of a road that follows the specifications of the Tanzanian Town and Country Planning Regulations.
- B** Identified as the division between north and south Tundu, this points close proximity to the CCM political headquarters makes this access point a preferable location.
- C** This access point is limited in terms of significant adjacent destinations and may cause problems with roadway implementation efforts because of its proximity to multiple structures.
- D** Locating an access point by these shops would draw economic activity to the southern area of town. This point lacks connection to development across the main road unlike point A.

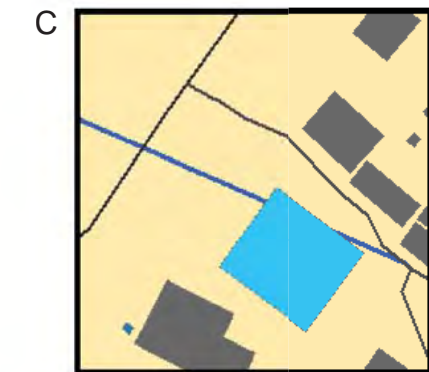
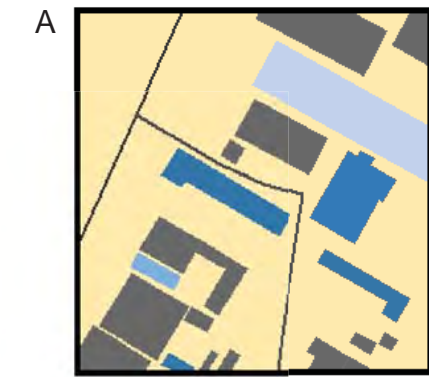

25 12.5 0 25 50 Meters

Distributor Road Route Options

Route 1:

- LEGEND**
- Rivers
 - Contours (20 Meters)
 - Railway
 - Major Paved Roads
 - Major Unsurfaced Roads

- Destinations**
- Other Buildings
 - Mosque
 - School
 - Maize Mill
 - Shop
 - Bikeshop
 - Bar
 - Church
 - Mr. Muchinguzi (Witch Dr.)
 - Cinema
 - Butcher
 - CCM Office
 - Public Cemetery

- Tundu Land Use**
- General Land
 - School
 - Market
 - Cemetery
 - Encroachment Conflict



NOTE: As depicted on the maps, route widths (15 meter right of way minimum) are standardized by the Tanzania Town and Country Planning Regulations.

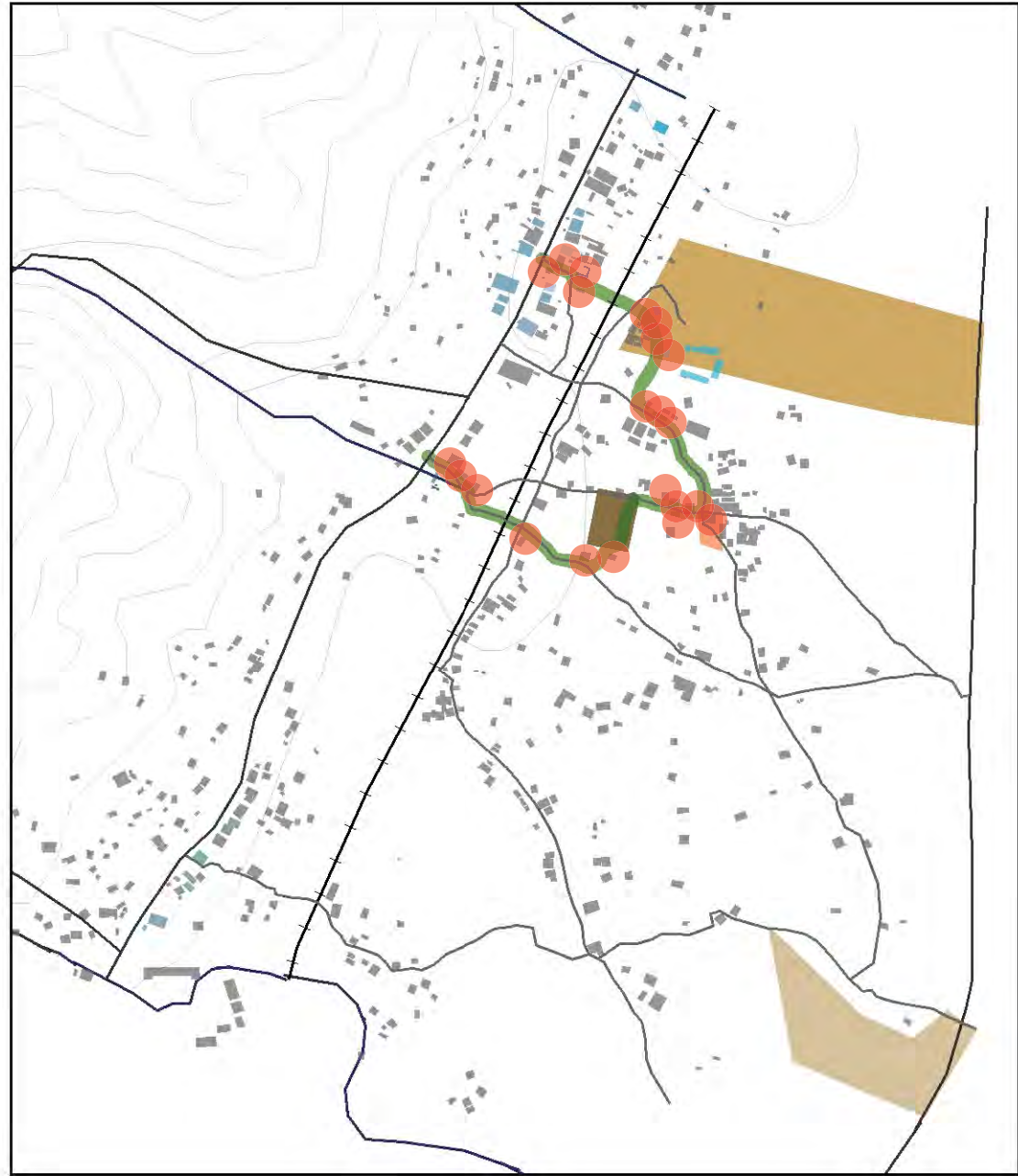

Extending from the main road and two existing entry points that are surrounded by many marked destinations, this route is focused on using existing infrastructure to the fullest extent. As the future determines the extent to which Tundu can feasibly implement the suggested routes, this option attempts to provide a small, low impact route that connects the majority of the major destinations of the village, including the school, market, and the general land.

Positives: Uses existing infrastructure, connects major destinations, low impact, cost efficient

Negatives: High level of building and property encroachment, concentrated location and short distance restricts diversity of users and uses

Route 2:

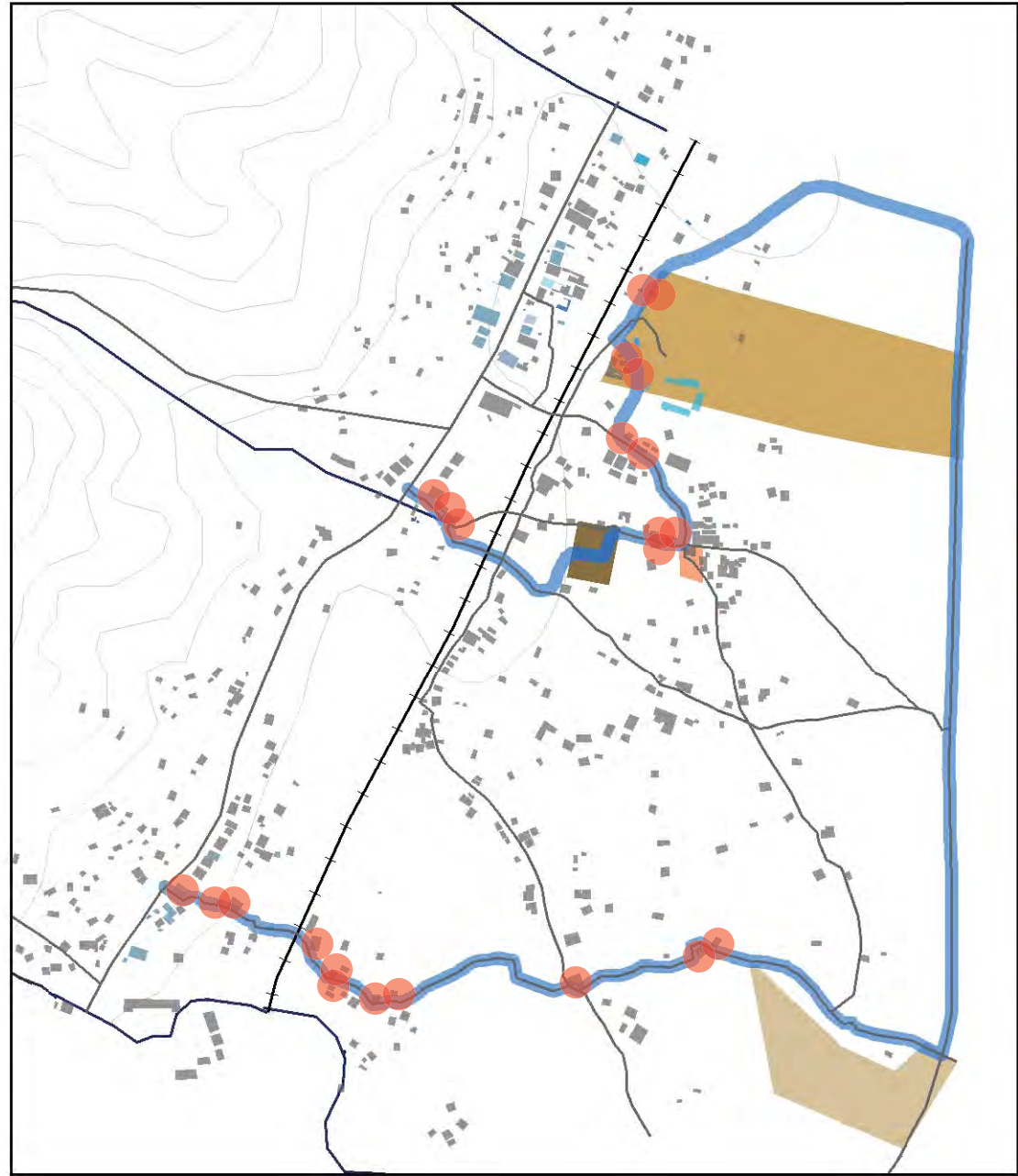

This route uses two existing entry points from the main road and strives to utilize existing infrastructure while expanding the range of the route to include major destinations of the market and school as well as the Illovo Sugar Cane Road and the southern portion of the village. It takes into consideration future land uses in that it runs along the future location of the public cemetery as well as the growing cane field area. As is already evident, development is and will continue to increase near the cane fields as the industry provides more economic opportunities for citizens.

Positives: Considers present and future destinations, accommodates future growth, expands roadway network to serve whole community, uses existing infrastructure

Negatives: High level of building and property encroachment, limited to current village perimeter resulting in the continued lack of inter-village connectivity

Addressing the 2 Meter Drop-Off: A Physical Barrier between the Main Road and Lower Portion of Tundu

While access points into the lower section of Tundu exist, access into this area is extremely limited and complicated by an abrupt two meter drop between the main road and the eastern side of the village. Transit between the western and eastern sides of the village is problematic, especially for vehicles. Hoping to improve access at these points, this project proposes that infill is used to create a more appropriate transition into the village. Recognizing the need for stabilizing such structures, a range of possible suggestions including planted slopes, gravel slopes, and gabions are proposed. Accommodating for proper drainage as well as road stabilization, the construction of regulation-based roadways leads to issues of encroachment that will need to be addressed if proper expansion and development is to occur.



Photos Courtesy of Orland 2010

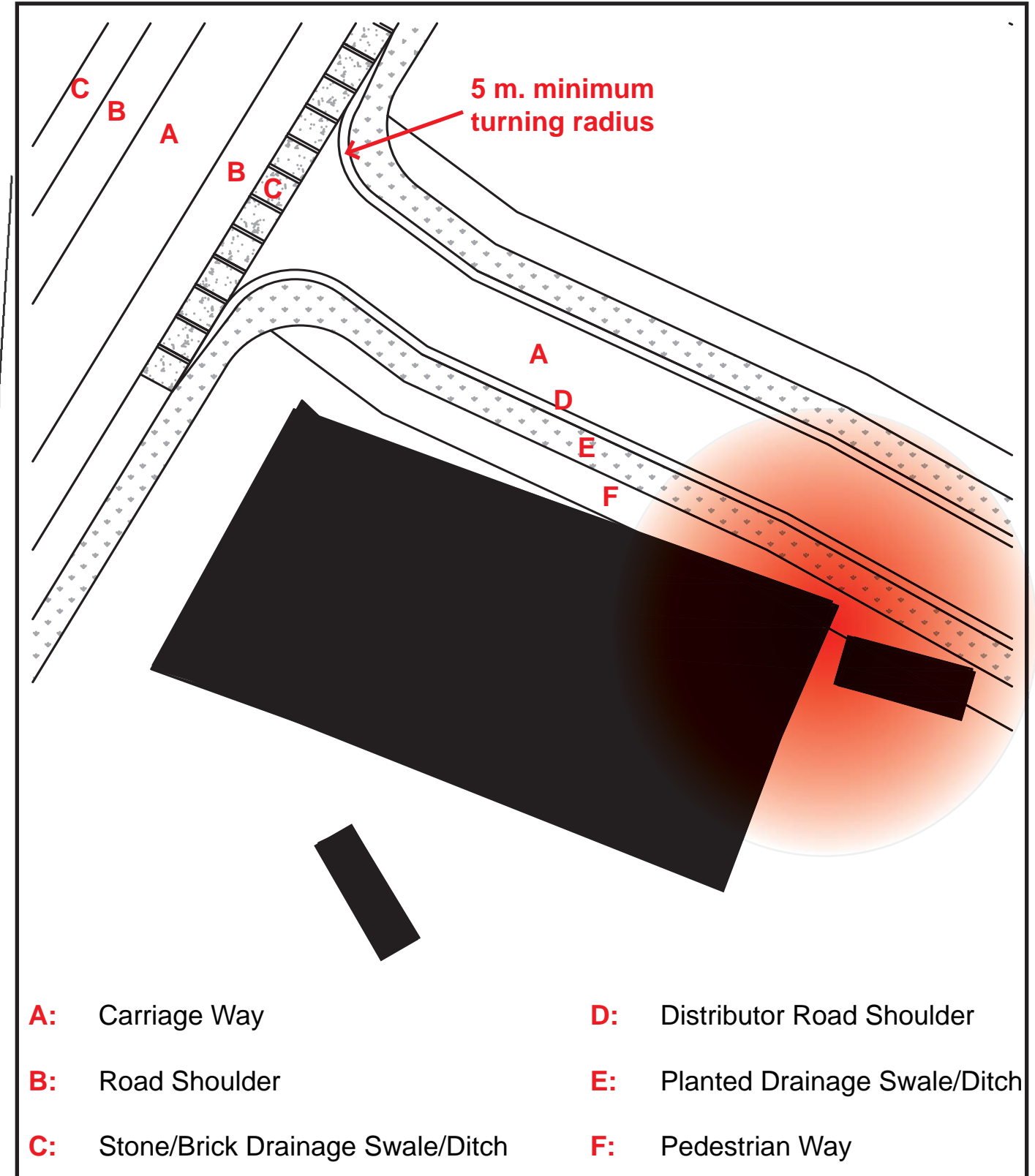
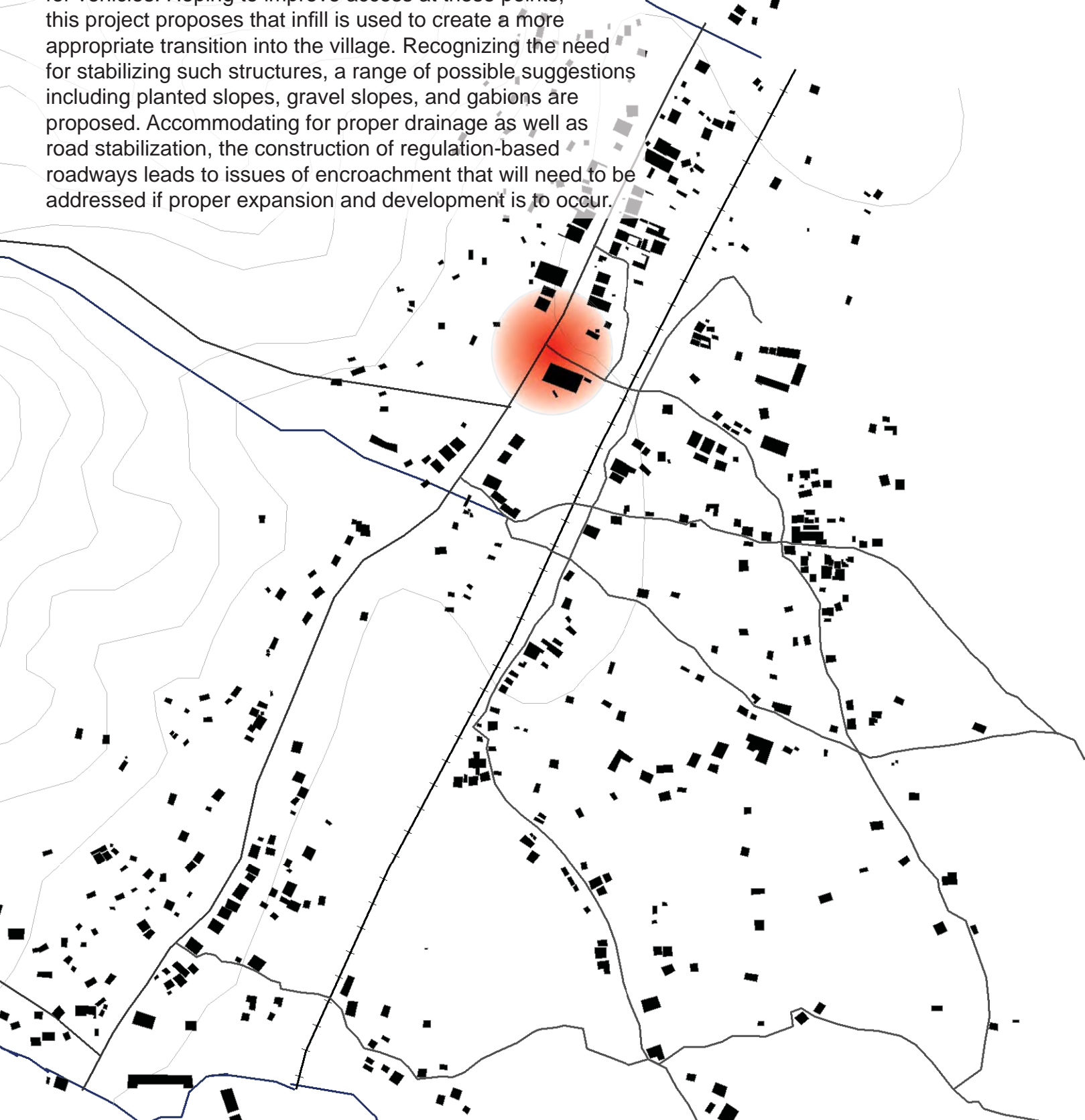

Addressing the 2 Meter Drop-Off: A Physical Barrier between the Main Road and Lower Portion of Tundu

Figure 7: Proposed Drop-Off Construction

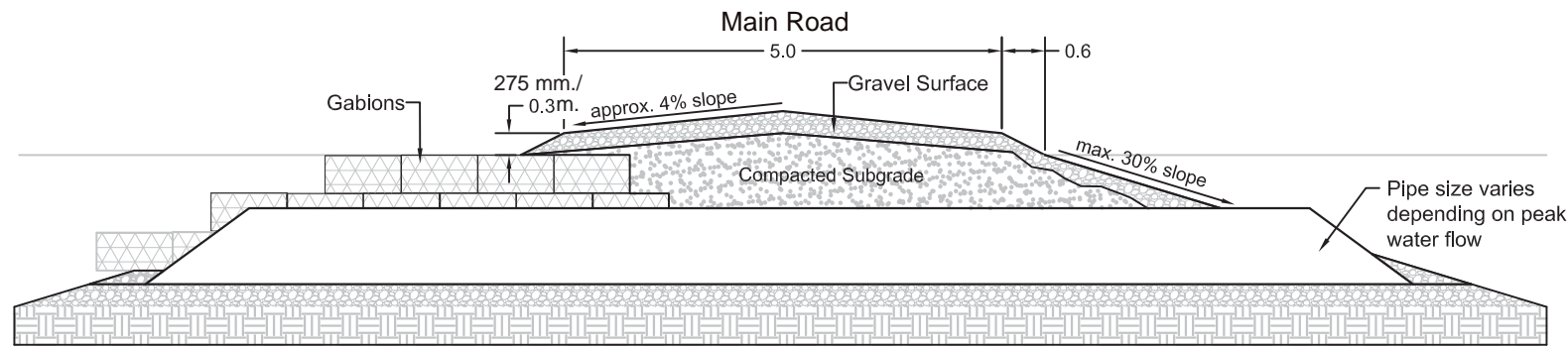

Option 1

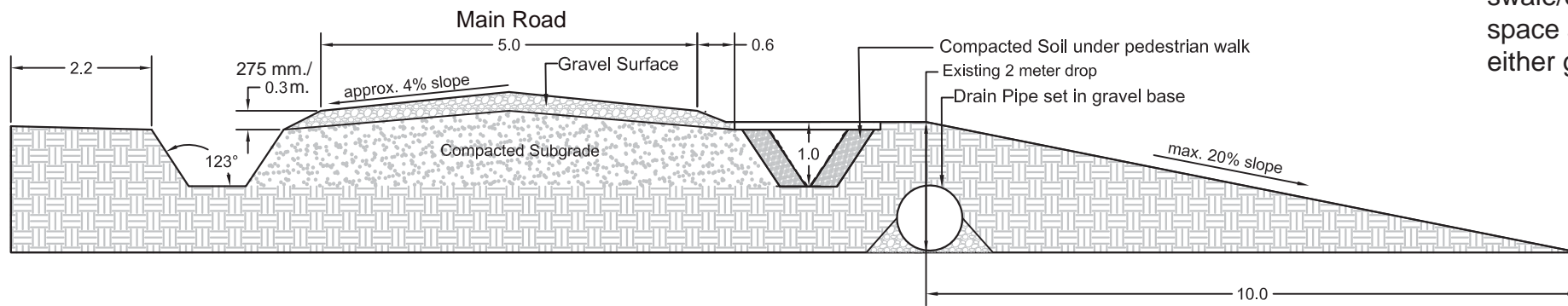

Option 2

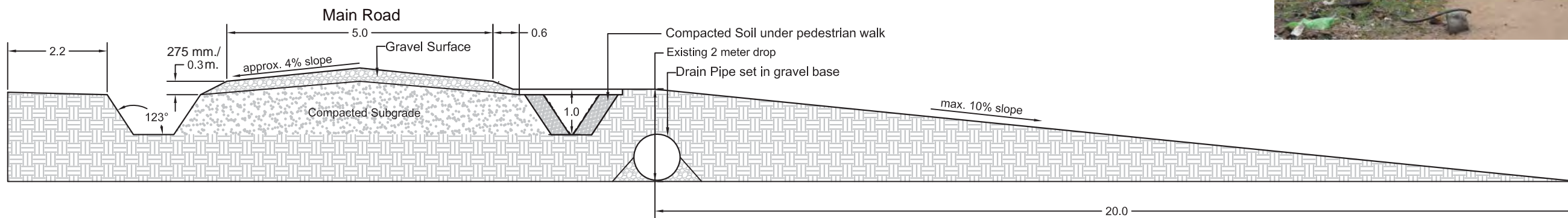

All Dimensions in Meters: None to Scale

The road sections in Figure 7 are the proposed solutions for the steep drop off that exists where the main road intersects with existing access points and the new distributor road. The sections feature the same concept, and only differ in the distributor road slope and length. Option 2 features a 10% sloped ramp, which will extend for a fairly long distance into the village. While its physical impact is greater, its gradual slope creates an easy transition. Option 1 will reduce ramp length, but creates an extreme condition at a 20% slope. While a 20% slope is possible and decreases impact, it improves traffic circulation minimally and poorly addressed drainage and erosion issues.

In order to address the transition in elevation, the ditch will be filled and graded to meet the desired slope for the road as proposed in options 1 and 2. Water management also needs to be considered at these complicated intersections and will be addressed using a combination of existing infrastructure as well as new construction elements. To achieve the ramp/drainage ditch combination, construction will first involve lining the ditch with a gravel bed. A drainage pipe will then be set on top of this gravel in order to allow for the continued flow of water beneath the road and in the swale/ditch. The pipe will be secured by the gravel bed and the remaining space around the pipe will then be filled with subgrade and topped with either gravel or gabions to ensure bank stabilization and longevity.



(Orland 2010)



As previously alluded to, the implementation of an organized, carefully, and appropriately designed circulation network will promote economic gain, improve inter and intra-village social systems, and with time, inadvertently contribute to the alleviation of poverty in Tundu and the conservation of nature within Udzungwa Mountains National Park and the Selous Game Reserve. In addition, the establishment of this circulation network will not only be essential for improving the current transit system, but will also influence future planning and growth, economic activities, and local livelihood within the village of Tundu.

Although the study is quite comprehensive, certain limitations restricted complete application accuracy. First and foremost, while a great effort was made to collect accurate and complete data for mapping purposes and analysis purposes, the data is slightly inaccurate and unrepresentative of the present conditions of the village of Tundu. Secondly, the lack of definitive property boundaries and current land use complicated the generation of route options. While proposed route locations respond to current needs, their exact location and implementation will need to be adjusted as additional and necessary information is gained and evaluated. In addition, while six transportation networks are suggested, the options are unlimited. Multiple route alternatives may be combined in order to meet community needs. Lastly, the implementation of standardized planning regulations complicated route identification. While it is recognized that these regulations are meant to standardize travel and development in response to population growth and the desire for sustainable development between humanity and nature, their implementation within existing settlements is difficult. As suggested by this study, the implementation of such standards results in numerous human and landscape encroachment conflicts. It is expected that this will be one of the largest obstacles in not only the construction of an improved and more organized roadway system, but also in future planning and development endeavors.

Recognizing the amount of energy and resources needed to implement such a network, this study presents numerous solutions that can be adjusted to meet both present and future community desires and needs. It is hopeful that phasing and funding initiatives can be adopted to help curb the expense of such a network. Phasing will answer immediate needs and provide timely benefits while allowing for continued feasibility and sustainable future expansion. Although limitations exist, Tundu's desire for improvement is a sign of increased environmental sensitivities. It is hopeful that in the future, improved and sustained expansion will be accepted and implemented.

While the present concern and focus of this project is on the village of Tundu, the issue of insufficient infrastructure is widespread throughout Tanzania. Although some of the design solutions suggested by this project are site-specific, the larger concept and approach of the project can be applied in villages that face similar issues throughout the country. The widespread implementation of defined and improved road networks throughout Tanzania will not only contribute to the feasible and efficient movement of both people and goods, but also of more representative political, economic, cultural, and social benefits and ideas. Overall, it is hopeful that these benefits will be popularly recognized, resulting in the increased desire for and appreciation of more forward thinking community planning that considers the integration of the environment, economy, and community.

REFERENCES:

Presidential Commission of Inquiry into Land Matters. 1994. Volume 1, Land Policy and Land Tenure Structure. The Ministry of Lands, Housing and Urban Development, Dar es Salaam (25).

Rwebangira, T., T. Pearce and DAC Maunder. 1999. Public Transport Safety in Tanzania. Transport Research Laboratory, UK Department for International Development.

Tanzanian Planning Commission. 1997. The Town and Country Planning (Town Planning Space Standards) Regulations.

All Tundu images are courtesy of Adrienne Angelucci, Larry Gorenflo, Brian Orland, Abigail Thomas, Rachel Tsupros, & Matt Weir.

